

Parts list NIROSTAR 2000-A

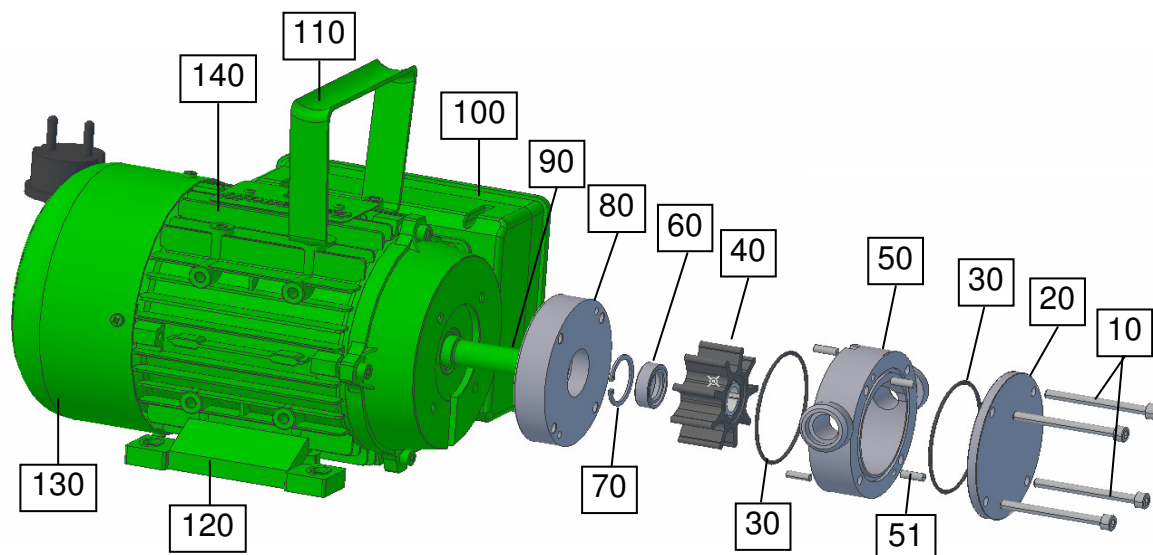

Pos.:	Part / Designation	Code	Number
10	Hexagon head screw M5x55	70324	4
20	Front cover NIROSTAR-A	11014301	1
30	O-ring 56-2 NBR	80003	2
30	O-ring 56-2 EPDM	80151	2
30	O-ring 56-2 VITON	80150	2
40	Impeller Perbunan type A / polyamid bush	11012909	1
40	Impeller Perbunan type A / stainless steel bush	11012908	1
40	Impeller Neoprene type A / stainless steel bush	11012505	1
40	Impeller EPDM type A / stainless steel bush	11012401	1
40	Impeller EPDM type A / polyamid bush	11012402	1
40	Impeller VITON type A / stainless steel bush	11012801	1
40	Impeller VITON type A / polyamid bush	11012810	1
40	Impeller plastic type A / polyamid bush	11012301	1
50	Housing NIROSTAR-A	11012605	1
51	Dowel 4x12 stainless steel	70268	4
60	Rotary shaft seal 14x26x7 NBR	80537	1
60	Rotary shaft seal 14x26x7 EPDM	80540	1
60	Rotary shaft seal 14x26x7 VITON	80538	1
70	Locking ring I 26x1,2 stainless steel	70167	1
80	Rear cover NIROSTAR/PF	11012703	1
90	Feather key A3x3x16	70315	1
100	Switch box motor 230V	80628	1
100	Switch box motor 400V	80630	1
110	Handle for motor	14000202	1
120	Motor base	FUSS00071	2
130	Ventilator cowl for motor BG71	80621	1
140	Motor 230V; 0,37 KW; 1400 rpm; complete	80600	1
140	Motor 230V; 0,37 KW; 2800 rpm; complete	80607	1
140	Motor 400V; 0,37 KW; 1400 rpm; complete	80605	1
140	Motor 400V; 0,37 KW; 2800 rpm; complete	80604	1



Dimensions NIROSTAR 2000-A

