

ZUWA Barrel Pumps

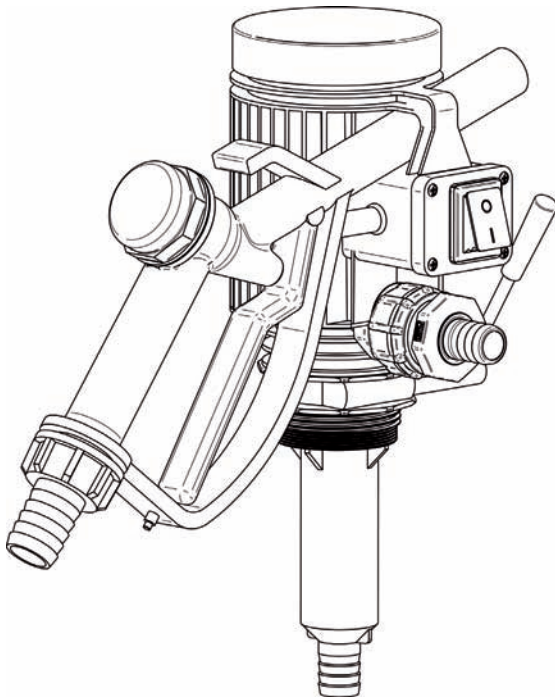

Barrel pump PICO

economic and efficient

Electric diesel pump for refuelling diesel-engined vehicles. Transports diesel fuel and fuel oil from barrels, tanks and containers. Provided alternatively with manual or automatic nozzle. By means of an extra small hand pump liquid is primed when starting the operation.

■ Features

- ▶ electric diesel fuel pump
- ▶ nozzle (automatic or manual)
- ▶ 4 m hose 3/4"
- ▶ foot valve
- ▶ connection cable
- ▶ optional: digital flow meter K24

■ Technical details pump

- ▶ approved media: diesel fuel, fuel oil, water, emulsions
- ▶ flow rate: 25 - 35 L/min (depending on power supply and nozzle)
- ▶ delivery pressure: max. 1 bar
- ▶ power supply: 12 V, 24 V or 230 V
- ▶ barrel connection 2"
- ▶ weight without accessories: 1,8 kg



*flow meter K24
(on option)*



*barrel pump for battery drive
including 3 m cable and clamps*

Barrel pump for battery drive 12 or 24 Volt

extremely lightweight and high capacity

The compact designed device is a tested and proven, dry self-priming ZUWA impeller pump. Depending on type it is suitable for various fluids like for example water, detergents, oils, diesel and fuel oil. Numerous applications in industry and agriculture, on building sites, for service cars of plumbing/heating installers etc. Rated for continuous duty application.

Highly functional: driving the pump with cordless drill or screwdriver.



ZUWA barrel pump *

■ Technical data

- ▶ high capacity, dry self-priming ZUWA impeller pump
- ▶ flow rate:
 - max. 15 litre/min with 12 Volt
 - max. 30 litre/min with 24 Volt
- ▶ delivery pressure: max. 3 bar
- ▶ dimensions H x W x L: 310 x 90 x 70 mm
- ▶ pump housing: aluminium (for acids and chemicals optionally also stainless steel)
- ▶ 3-pin connector plug
- ▶ on/off switch with thermal motor protection
- ▶ 5 metres cable
- ▶ optional: 2" barrel adaptor - suitable for all standard barrels
- ▶ **weight: only 3,1 kg**

Barrel pump with electric drive

versatile and reliable

This high quality, dry self-priming impeller pump is suitable for all kinds of non-abrasive and non-corrosive fluids – particularly for oils and diesel. With the flexible impeller wheel the pump is insensitive to solids within the fluid. The pump is capable of draining barrels down to the last drop. Different flow meters optionally available.



ZUWA barrel pump *

■ Technical data

- ▶ dry self-priming ZUWA impeller pump UNISTAR 2000 with flow rate:
 - max. 30 litre/min (UNISTAR 2000-A)
 - max. 60 litre/min (UNISTAR 2000-B)
- ▶ delivery pressure: max. 5 bar
- ▶ power supply: 230 oder 400 Volt
- ▶ pump housing: aluminium
- ▶ weight: 9 - 10 kg

* barrel and battery not included



ZUWA-Zumpe GmbH Pumps and Sprayers

Franz-Fuchs-Straße 13 - 17 • D-83410 Laufen
Fon: +49 (0)8682 89340 • Fax: +49 (0)8682 893434
E-mail: info@zuwa.de • Internet: www.zuwa.de