



Operating Instructions WÜMA
Vole Fighter

WÜMA – vole fighter with 2 stroke engine 72/4cc – 3,7 kW

Operating Instructions Edition 04/2010 - Translation

Content

1. Declaration of conformity	3
2. Introduction	4
2.1 Description of the machinery	4
3. Safety	4
3.1 Intended use	4
3.2 General safety instructions	4
3.3 Legend.....	5
4. Transportation and unpacking	5
5. Commissioning	5
5.1 Assembly	5
5.2 Mixing fuel	5
5.3 Filling the Tank	6
5.4 Starting the Motor	6
5.5 When the engine is flooded	6
6. Operation.....	7
7. End of operation	7
8. Cleaning and Storage.....	8
9. Maintenance	8
9.1 Carburetor	8
9.2 Air cleaner	8
9.3 Fuel filter.....	8
9.4 Engine	8
9.5 Spark plug	8
9.6 Protective grid.....	8
9.7 Wartungstabelle.....	9
10. Troubleshooting.....	10
11. Disposal.....	10
12. Technical data	10
13. Parts list.....	11

1. Declaration of conformity

Declaration of conformity

according to machinery directive 2006/42/EC annex II A

The manufacturer ZUWA-Zumpe GmbH
 Franz-Fuchs-Straße 13-17
 D-83410 Laufen

hereby declares that the following products

product name: **WÜMA Vole Fighter**
types: **WÜMA Vole Fighter**
series: **WÜMA with 2 stroke engine 72/4cc – 3,7 kW**

comply with the provisions of the above-mentioned CE Directive(s) including the amendments valid at the time of declaration.

The following harmonised standards have been applied:

EN 294:1992	Safety of machinery. Safety distances to prevent danger zones being reached by the upper limbs
EN ISO 12100-1:2003	Safety of machinery - Basic concepts, general principles for design Part 1: Basic terminology, methodology
EN ISO 12100-2:2003	Safety of machinery - Basic concepts, general principles for design Part 2: Technical principles

The following EC directives have been applied:

2004/108/EC EMC Directive
97/68/EC Directive on emissions from non-road mobile machinery
2004/26/EC Directive on emissions from non-road mobile machinery
2000/14/EC Directive on the noise emission in the environment by equipment for use outdoors

Person authorized for the compilation of the technical documentation:	Jürgen Huber
	ZUWA-Zumpe GmbH
	Franz-Fuchs-Straße 13-17
	D-83410 Laufen

Ort: 83410 Laufen
Datum: 08.02.2010

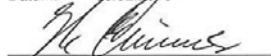
(Unterschrift)
Geschäftsführer

(Unterschrift)
Leitung Technik

2. Introduction

This manual provides important information for a safe and correct operation of the vole fighter WÜMA. The manual is bound/intended for all users of WÜMA.

Store these instructions in such a way that they are accessible at all times for operating personnel.

2.1 Description of the machinery

The vole fighter WÜMA consists of a cart, a 2 stroke gasoline motor with fan, a hose with probe, tank and two search rods.

The device is adjusted to create sufficient gas for fumigating voles along with a sufficient amount of smoke required to ease the process. Gas is created without any additives.

A system of valves combined with a specifically adjusted fan the concentrated gas is accelerated and introduced into the vole tunnels. The voles have no time to escape from the gas. With the special ZUWA probe the gas is introduced precisely and safe into the tunnels.

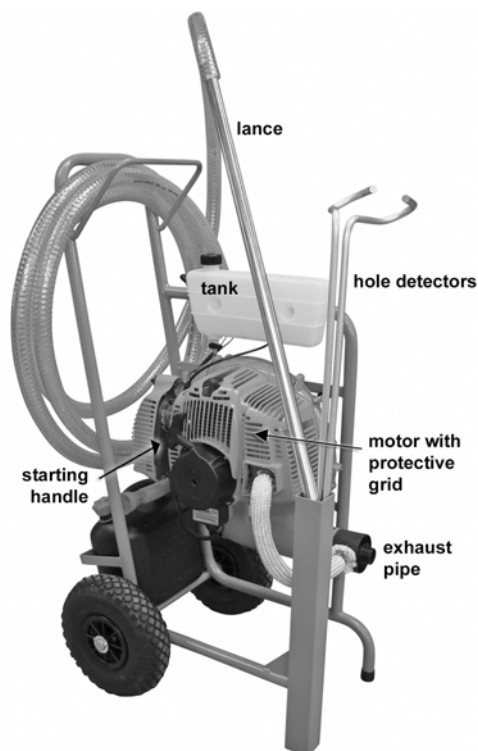

3. Safety

3.1 Intended use

WÜMA vole fighters are designed to fumigate voles by introducing carbon monoxide into the vole's tunnel systems beneath the surface.





For outdoor use only!

Fumigation may be prohibited in water protection areas. Contact your local officials for more information.

3.2 General safety instructions

- Never point the probe toward humans or animals when in operation.
- Never leave the device unattended when motor is working.
- Work on the device only when the device is turned off and the motor cooled.
- Protect cables and hoses against heat and sharp edges.
- Check cable and hoses regularly for damage (visual inspection) and replace defective components.
- Do not fix any auxiliary equipment to the device without the permission of the manufacturer.
- Repair and maintenance works must only be done by skilled personnel.
- Use genuine spare parts only, otherwise the warranty shall cease to be valid.

3.3 Legend

 Danger	Hazard with increased risk which leads directly to fatalities or severe injuries if not avoided.
 Danger	Risk of fatalities and severe injuries caused by electric shock.
 Warning	Hazard with medium risk which could lead to fatalities or severe injuries if not avoided.
 Caution	Hazard with minor risk which can lead to minor injuries or material damage if it is not avoided.
 	Information, note



5.2 Mixing fuel

The WÜMA is driven by a 2 stroke engine requiring a mixture of gasoline and oil for 2 stroke motors.

Recommended fuel: The motor is certified for the use with unleaded gasoline 89 Octane ([R + M] / 2) or higher. Use oil for 2 stroke engines only (do NOT use machine oil or oil for 2 stroke outboard engines).

- Danger of death due to explosion**
- > No open flames or smoking near to the device or fuel container.
- Danger**
- > Mix fuel outdoors only .

4. Transportation and unpacking

Weight vole fighter with accessories: 27,5 kg

- > After unpacking, immediately check the device for completeness and damages.
- > Immediately report any transit damage to the supplying company.
- > Dispose of packaging material according to local environmental regulations.

Danger of death due to explosion

- > Do not transport the device with running engine.
 - > Do not transport device in horizontal position to prevent leaking of fuel.
- Danger**
- > Fix the device tightly to vehicle during transport.

- Information**
- Observe the following mixing ratio accurately to make sure a sufficient quantity of gas is produced to kill the voles.
- > Mix oil for 2 stroke engines in a ratio of **1:25** (4% oil, 96% gasoline)
 - > Mix unleaded gasoline and oil for 2 stroke engines in a clean container, approved for the use with gasoline.
 - > Shake the tightly closed container.

Danger of death due to explosion

- > Store the fuel in a tightly closed container approved for the use with gasoline at a dry, cool place.
- Danger**
- > Store device and fuel at a place where fuel vapours can not be ignited by sparks, flames, boilers, electric motors, switches, heaters etc.

5. Commissioning

5.1 Assembly

The WÜMA is ready to use after fixing the exhaust hose to the tail pipe.



2 stroke engine oil contains fuel stabilizers, the mixture can be used for 30 days. Do not mix more fuel than you will use within 30 days.

5.3 Filling the Tank

Danger of death due to explosion



Danger

- > Turn off the motor before filling the tank. NEVER fill fuel into a device with working, hot motor.
- > Check for leaks and make sure no fuel is escaping prior to using the device.

Maximum filling capacity of the tank is 1,7 litres.

- > Shake the container with the fuel mixture prior to filling the tank.
- > Open the tank lid slowly.
- > Fill fuel mixture carefully into the tank. Check seal and clean if necessary before closing the tank.
- > Put on lid and fix it tightly by hand. Wipe off spilled fuel.

5.4 Starting the Motor

Danger of injury due to grazing or jamming by the impeller



WARNING

- > Do not wear loose fitting clothing, no scarf, no neck tie or anything that might enter into the air intake through the safety grid.
- > Never put your hands into the air intake.

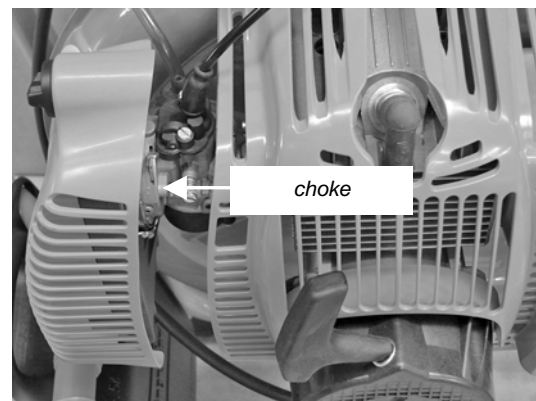
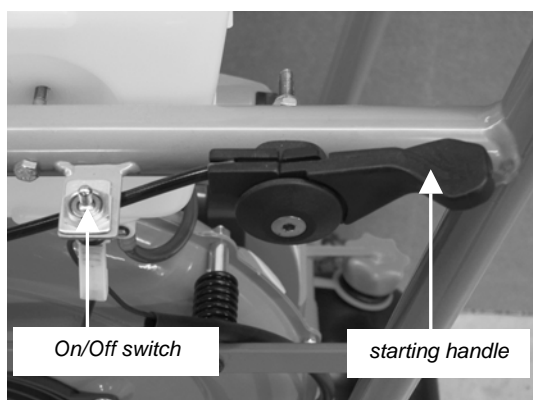

- > Put the hand throttle not higher than medium position.
- > Put the ON/OFF switch into the START position.
- > Open valve beneath the the tank by setting it to «ON».
- > Put choke to «CLOSE» (with cold motor only).
- > Hold the device tight and pull the Start handle slowly till you can feel a resistance. Then pull hard till the engine starts.
- > Shift the choke to «OPEN» till the engine runs smoothly.
- > Let the engine run at full throttle.



Do not use the choke when motor is warm to avoid flooding.

During operation the motor needs to smoke to guarantee the fumigating effect.

5.5 When the engine is flooded

- > Put the ON/OFF switch to position «STOP».
- > Remove spark plug socket using the tool received with the WÜMA.
- > Unscrew and dry the spark plug.
- > Pull throttle to dead stop.
- > Pull start rope several times to vent the carburetor.
- > Insert the spark plug and attach the spark plug socket; press to a tight fit.
- > Put the ON/OFF switch to START.
- > Set the choke to position «OPEN» - even if motor is cold.
- > Start the engine using the starting handle.

6. Operation



DANGER

Danger of death due to inhalation of carbon monoxide

- > Use device only outdoors.

Danger of death due to explosion

- > No open flames or smoking near to the device or fuel container.



Danger

Danger of death due to electric shock

- > Never work close to electric power supply cables or buildings.



WARNING

Danger of burn due to hot exhaust pipe

- > Do not touch exhaust pipe or hose connection during operation or cooling down.



Under regular working conditions the device can emit a sound level of 85 dB(A) or more. It is strongly recommended to wear ear protection during operation



Voles protect themselves with a specific tunnel system against intruding water during rain falls. Fumigation during rain or when ground is wet is not recommended.

Fumigation per tunnel takes 3-5 minutes, slightly longer when ground is loose.

- > Open tunnel and insert probe. Support the probe with the search stick.

Via the probe the gas is introduced into the tunnel. When smoke emerges from the ground it is secured that the complete tunnel was fumigated.

- > Look for further tunnels during the fumigation period with the second search stick.



Caution

Danger of material damage

- > Do not move the device by pulling it using the hose.

- > Put throttle to the top when you move the device.



Mark fumigated areas with pieces of wood or similar to have a better overview.

Check the fumigated area a few days after the first fumigation. Repeat process in case you encounter further vole activity.

7. End of operation

Switching off the engine

- > Put throttle to engine idle.
- > Close the valve of the fuel tank by setting it to the «OFF» position.
- > Put the ON/OFF switch of the the motor to «STOP».

8. Cleaning and Storage

- > Clean probe by removing dirt with the search stick.

When device is not used for longer time:

- > Drain and clean fuel tank in a well vented environment.
- > To drain the carburetor start the engine and let it come to a standstill (remaining fuel in the carburetor may damage the membranes).
- > Clean protection grid, air filter, motor and hoses.
- > Remove the empty tank.
- > Remove spark plug and put some oil into the cylinder.
- > Pull the start rope several times to turn the motor shaft. The oil is scattered inside the cylinder
- > Put the spark plug back into the cylinder.
- > Store the device dry and cool, if possible elevated from the ground

Apply the normal starting procedure after a longer break.

9. Maintenance



WARNING

Danger of scald burn due to hot engine

- > Wear protective gloves for maintenance work.
No maintenance work with hot engine.

Never do any repair works apart from regular maintenance jobs. Have reparations done by qualified personnel only.

Remove the spark plug socket prior to any cleaning or maintenance works.

9.1 Carburetor

Do not make any amendments on the carburetor.

The engine idle screw is set to an operation speed of 2700 rpm.

9.2 Air cleaner

When a substantial reduction of motor power occurs the air filter may be choked or damaged. Replace the component.

- > Before the new filter is assembled remove dirt from the inside of the lid and the surroundings of the filter.

9.3 Fuel filter

The fuel filter is located beneath the carburetor connection. It needs to be checked in regular intervals. A dirty filter causes problems during the start and a reduction of engine power.

Cleaning is recommended after 50 working hours. Please proceed as follows:

- > Remove screw (left picture), connection and filter carefully



- > Clean filter with a non inflammable cleaning liquid (for example luke warm soap solution) and dry it.

9.4 Engine

Sedimented dirt on the cylinder can cause overheating of motor and malfunctions.

- > Clean cooling fins periodically with a brush or compressed air.

9.5 Spark plug

- > Clean spark plug periodically and check distance of the electrode.

9.6 Protective grid



Danger

Danger of injury due to abrasion or crushing by the impeller

- > Do not remove the protective grid when the engine is running.

- > Clean grid of the impeller periodically and remove all sedimentations or dirt.

9.7 Wartungstabelle

Please note - the following maintenance intervals are valid for a regular use only. In case you operate the device under harsh conditions these intervals need to be reduced accordingly		Prior to each use	After each fuelling	At the end of the working day	Weekly	Monthly	When damaged or defect	If required
Complete device	Check for leaks, cracks, wear and tear	X	X					
	Cleaning			X				
Inspect: switch, starter, throttle and lever	Operational reliability	X	X					
Fuel tank	Check for leaks, cracks, wear and tear	X	X					
Fuel filter	Inspect and clean					X		
	Replace filter						X	Every 6 months
All accessible screws and nuts (apart from carburetor screws)	Inspect	X						
	Tighten				X			
Air filter	Clean	X						X
	Replace						X	Every 6 months
Starter cable Shoulder belt	Inspect for damages, wear and tear				X			
	Replace						X	
Carburetor	Check idle speed	X	X					
Spark plug	Check distance of electrode					X		
	Replace						X	Every 6 months
Anti vibration system	Inspect for damages, wear and tear				X			
	Replace by authorized service station						X	
Seals	Inspect and replace if required					X		

10. Troubleshooting

Fault	Possible cause	Remedy
Motor does not start or stops after a few seconds (make sure the switch is set to "I")	No ignition spark	Check spark. In case no ignition spark is produced try with new spark (BPMR7A)
	Engine flooded	Follow procedure in chapter 0. In case motor does not start try with new spark
Motor starts, but does not accelerate correctly or does not work well in high motor speed	Air cleaner clogged	Clean device (see guidelines in chapter 9.2)
	Carbureter needs adjustment	Have carbureter adjusted in an authorised repair shop
Motor does not reach maximum working speed or smokes excessively	Oil-fuel mixture too cold or inappropriate	Use oil and fuel suitable for 2-stroke engines
	Air cleaner clogged	Clean device (see guidelines in chapter 9.2)
	Carbureter needs adjustment	Have carbureter adjusted in an authorised repair shop
Motor starts, accelerates and works, does not keep idle speed though	Carbureter needs adjustment	Have carbureter adjusted in an authorised repair shop
Motor starts and works, emits a too small air stream though	Grid on impeller is clogged	Clean grid
	Impeller is damaged	Have impeller repaired or replaced by an authorized repair shop

11. Disposal

Most components of the device can be recycled.

All metals (steel, aluminium, brass) may be disposed off at any scrap metal dealer

Observe the local regulations. For further information contact your garbage removal service

12. Technical data

Dimensions (H x W x D)	104 x 48 x 60 cm
Weight complete including accessories	27,5 kg
Tank content	1,7 litres
No-load speed engine	2,700 rpm
Max. speed	6,000 rpm
Sound pressure level	85 dB(A)

13. Parts list

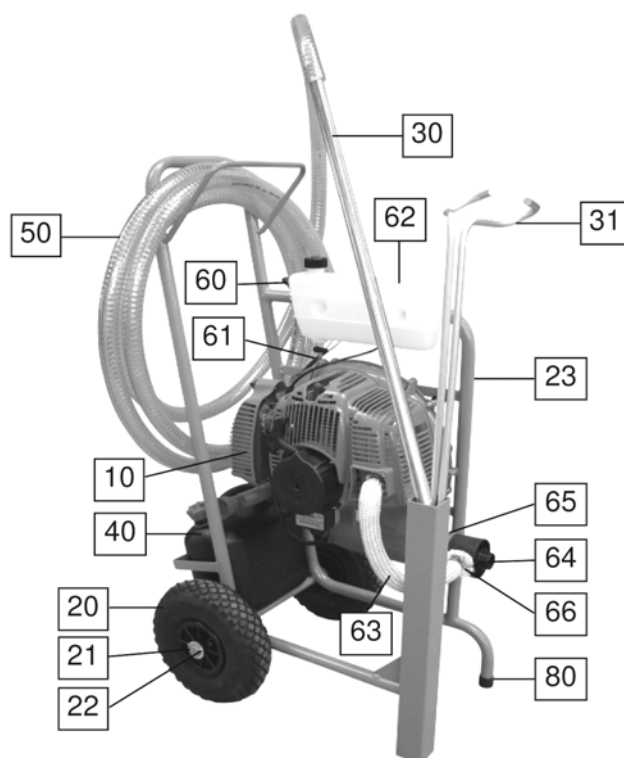

Pos.:	Part / Designation	Code	Quantity
10	2-stroke engine 72,4 cc (3,7 KW) with fan	40000123	1
20	inflatable wheel	80120	2
21	washer 21 x 33 x 2,5 mm	70101	2
22	eyebolt 3,2 x 32 mm	70308	2
23	chassis WÜMA RAL 6011	40000115	1
30	lance for WÜMA	40000112	1
31	hole detector for WÜMA	40000111	2
40	petrol tank	80368	1
50	spiral hose length 6 m	30035	1
60	throttle for motor	365100024	1
61	motor cables, set	365200153	1
62	petrol tank WÜMA	365200113	1
63	heat protection (exhaust pipe mantle) length = 33 cm	262626	1
64	exhaust deviation complete for WÜMA	40000116	1
65	hose clamp 70-90 mm	80279	1
66	hose clamp 20-32 mm	80245	2
70	hose connection 25 R1"	131212	1
80	rubber pads	80543	1

Manufacturer:

ZUWA-Zumpe GmbH - Pumps and Plant Protection Equipment

Franz-Fuchs-Straße 13 – 17

D-83410 Laufen

Phone: +49 8682 89340

Fax: +49 8682 893434

e-mail: info@zuwa.de

internet: www.zuwa.de